

Models CTD-1 & CTD-2

Capacitor Trip Devices

Application

Provides a source of energy for circuit breaker and switch trip coil operation during a loss of AC control voltage.

Normal Input

120 Volts ac,
125 Volts dc.

Frequency

DC to 400Hz.

Specifications

Max. Input Voltage:

140 Vac, 125 Vdc surge protected.

Capacitance:

330 uF, CTD-1 $\pm 20\%$ @ 25 °C
1,500 uF, CTD-2 $\pm 20\%$ @ 25 °C
Available Energy (**)
4.72 joules, CTD-1
 $\pm 20\%$ @ 25 °C.
21.5 joules, CTD-2
 $\pm 20\%$ @ 25 °C.

Normal Output Voltage(**)

170 Vdc (120 Vac input)
125 Vdc (125 Vdc input)

Normal Charge Time (*)

170 msec. CTD-1
440 msec. CTD-2

Operating Temperature Range:

-30 °C to 60 °C

Storage Temp Range:

-50 °C to 80 °C

Short Circuit Protection:

Continuous

Mounting:

Vertical or horizontal

Input Surge Protection:

MOV protected to 65 joules pulse surge

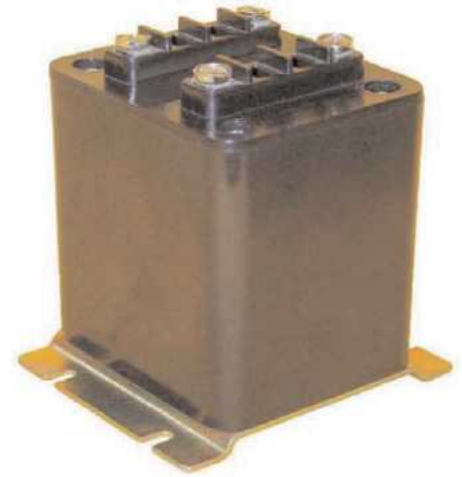

REGULATORY AGENCY APPROVALS



These devices are protected against inadvertent output short circuit, inductive kickback from the trip coil, and input line voltage surges. Nominal 120 Volts ac, or 125 Volts dc is applied between the 'AC' and 'COM' terminals. This voltage is half wave rectified and applied across the trip capacitor, giving an output trip voltage. The charge stored in this capacitor (330 uF or 1,500 uF) is available between the '+' and 'COM' terminals for breaker trip coil operation. The half wave rectification circuitry provides the advantage of maintaining a common neutral connection from input while still maintaining the charge in the the trip capacitor after control power is lost.

The capacitor is continuously charged when control power is available, providing energy for normal trip coil operation. Because mechanical relays are not involved, energy for the trip coil operation is immediately available with the loss of control power. When the control power returns, the capacitor automatically charges to supply energy for the next trip coil.



Models CTD-1 & CTD-2

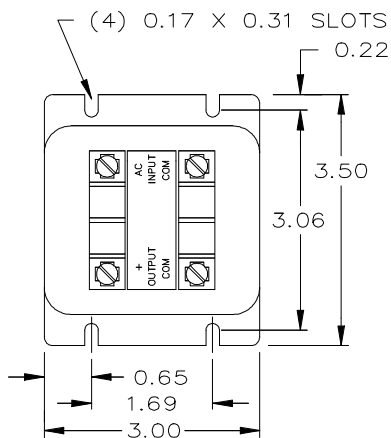
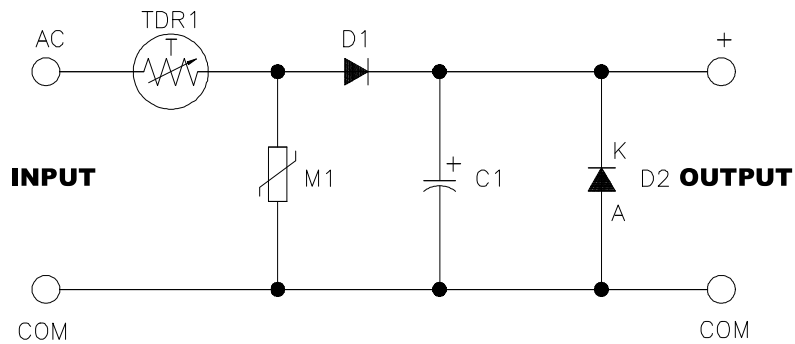
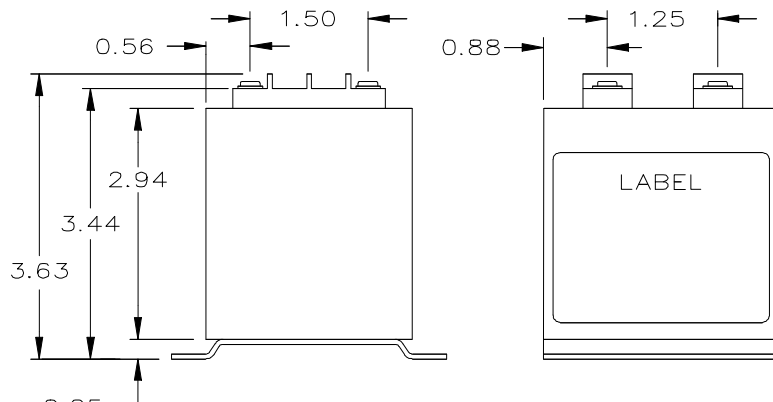

* Charge time from full discharge to 90 % of max. capacitor voltage at 25 °C.

** Trip capacitor fully charged to nominal ac input voltage.

Grid-AIS-L4-ITL_Model_CTD-1069-2017_06-EN. © Copyright 2017. General Electric Company and Instrument Transformers LLC reserve the right to change specifications of described products at any time without notice and without obligation to notify any person of such changes.

